

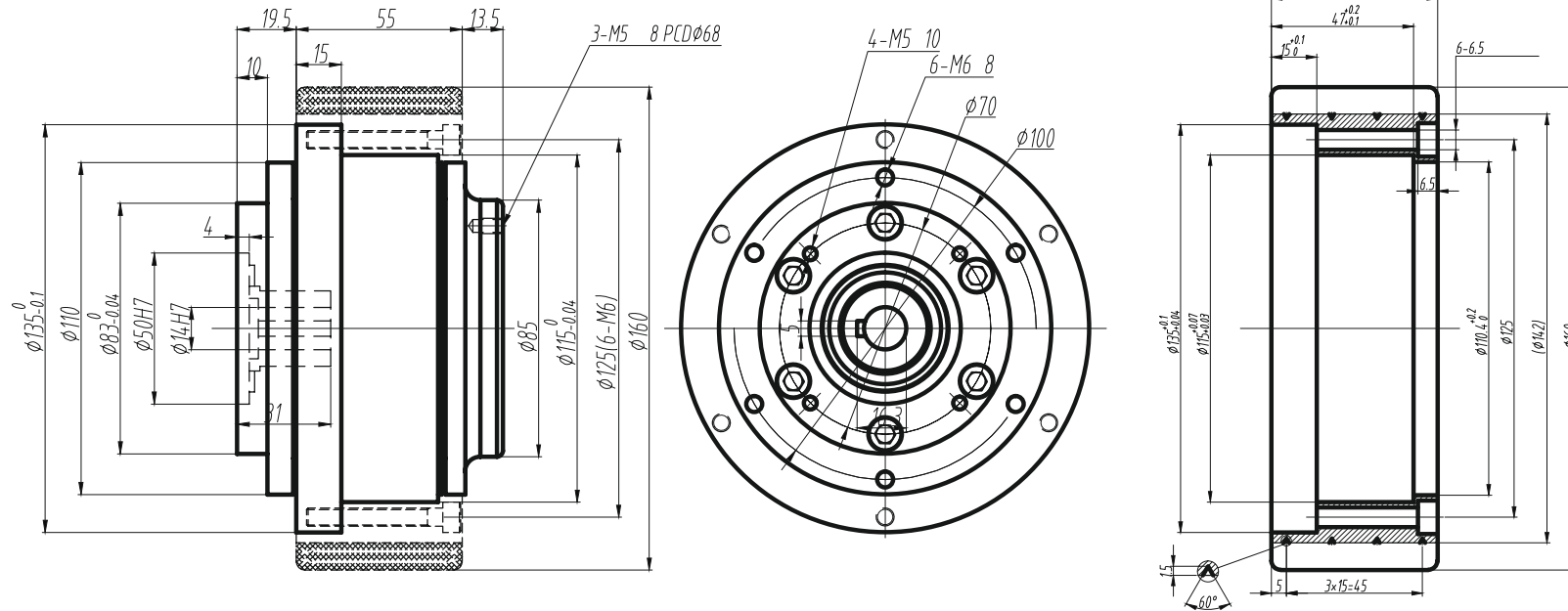

Date	Description	Revision



technical parameter			
Nominal torque	60 Nm	Max.output torque	120 Nm
Rated input speed	3000rpm	Max.input speed	5000rpm
Max.radial force	400N Speed 500rpm	6800N Speed 150rpm	
Max.axial force	500N Speed 500rpm	850N Speed 150rpm	
Maximum efficiency	90%	Operating temp	-25°~ + 90°
Installation method	arbitrarily	Lubrication mode	Permanent lubrication
Weight	5.5Kg+ 2.5Kg	Average life span	20000h
Protection level	IP64	Flange accuracy	DIN 42955-R
Standard backlash		Precise backlash	
Gear precision grade	6 GB/T10095-2008		
Motor power	400W		
Motor dimensions	φ14*30/φ50*3/4-φ5.5-φ70		

No.	Part No.	Description	Unit	Qty

	JVL www.jvl.dk	JVL A/S Bregnerødvej 127 DK-3460 Birkerød Tel: +45 4582 4440 Email: jvl@jvl.dk	A4	File name:
				Part no.
				HSHVA6N030MLNS605_A6
Drw	Sign+vv	Date	Unit	Tolerances Unless Specified Linear 0.5~6 ±0.1 6~30 ±0.2 >30 ±2% Angles ±3°
App			mm	
ERP			Scale --	
				Description AGV Ø160mm gear 30:1 MAC402 <15'