

Date	Description	Revision

P1

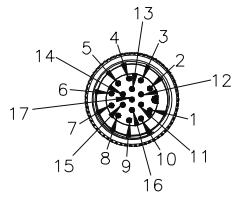

Detailed Product Description:
 Waterproof connector rating is IP67
 They can not be used permanently under water
 Per ISO-20653,IEC60529

Destructive withstand force between connector and overmold exceeds 2.0kgf.

Connector Electrical character
 Rating voltage: 30V

Insulation resistance: >100MΩ

Contact resistance of connector ≤10mΩ

Mechanical characteristics: mating / cycle >100cycle

Operating temperature: -25°C ~ +85°C

TESTING CONDITIONS:

- VOLTAGE: 300V DC/0.1S
- 100% OPEN AND SHORT ELECTRICAL TEST

ALL MATERIALS ARE RoHS COMPLIANT

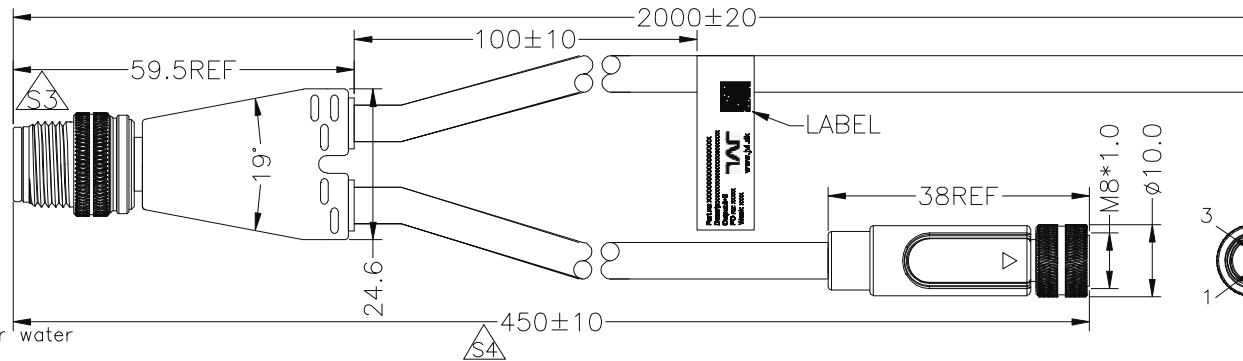

P2

P3

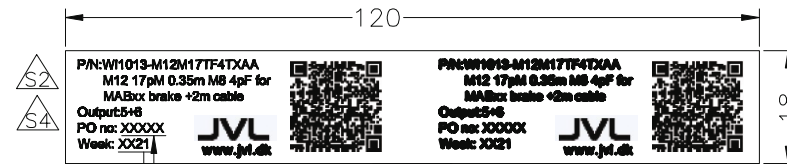



Change according to actual production cycle Adjust according to order batch CABLE LABEL

Label A specification description:
 1. Materials: PET, white and black.
 2. Maximum text height: 3mm, The font "Arial"

WIRE LIST

P1	COLOR	P2	P3
1	WHITE	OPEN	/
3	BLUE		
4	BLACK		
9	GRAY		
2	BROWN		
16	BROWN		
11	WHITE	/	2
12	BLUE		
SHELL	BRAID	OPEN	SHELL

	 www.jvl.dk	JVL A/S Bregnerødvej 127 DK-3460 Birkerød Tel: +45 4582 4440 Email: jvl@jvl.dk	A4	File name: {file name}		
				Part no. WI1013-M12M17TF4TXAA		
Drw	Sign+vv	Date	Unit	mm	Tolerances Unless Specified Linear 0.5~6 ±0.1 6~30 ±0.2 >30 ±2% Angles ±3°	Description Brake cable
App			Scale	--		
ERP						

No.	Part No.	Description	Unit	Qty