

Date	Description	Revision

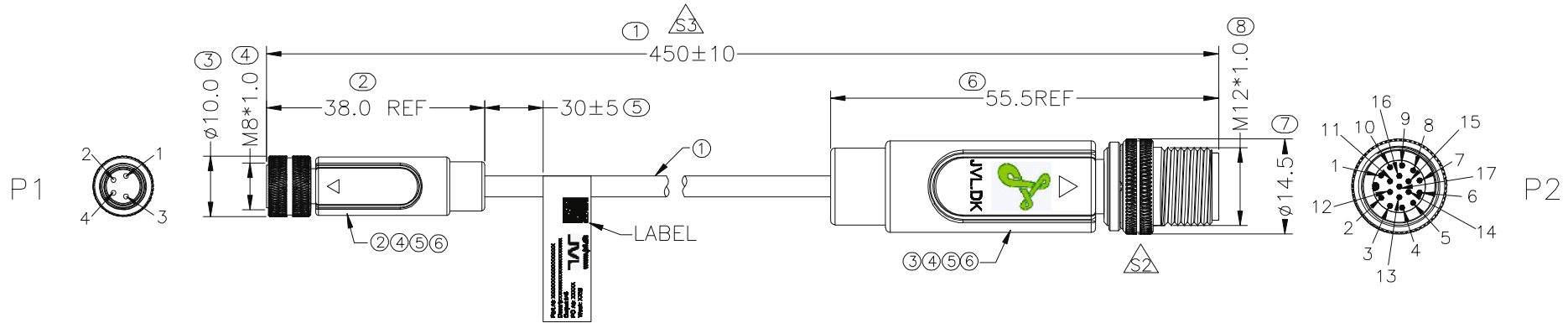

Detailed Product Description:
 Waterproof connector rating is IP67
 They can not be used permanently under water
 Per ISO-20653, IEC60529
 Destructive withstand force between connector and overmold exceeds M8:2.0kgf, M12:5.0kgf.
 Connector Electrical character
 Rating voltage: 30V
 Insulation resistance: >100MΩ
 Contact resistance of connector ≤10mΩ
 Mechanical characteristics: mating / cycle >100cycle
 Operating temperature: -25°C ~ +85°C

TESTING CONDITIONS:
 1. VOLTAGE: 300V DC/0.1S
 2. 100% OPEN AND SHORT ELECTRICAL TEST

ALL MATERIALS ARE RoHS COMPLIANT

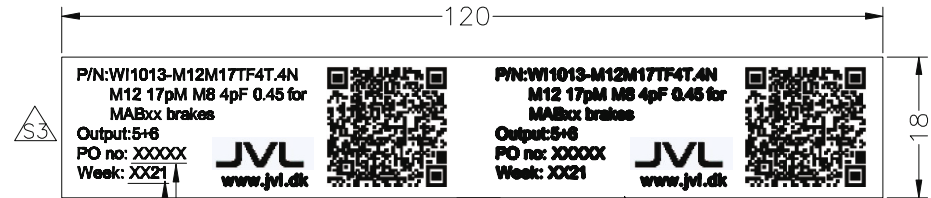

Change according to actual production cycle (S3) Adjust according to order batch (7) LABEL

Label A specification description:
 1. Materials: PET. white and black.
 2. Maximum text height: 3mm, The font "Arial"

WIRE LIST

P1	COLOR	P2
2	WHITE	11
2	BLUE	12
1	BROWN	16
1	BROWN	2
SHELL	BRAID	SHELL

No.	Part No.	Description	Unit	Qty	Sign+vv	Date	Unit	mm	Tolerances	Description
					Drw				0.5-6 ±0.1	
					App				6-30 ±0.2	
					ERP				>30 ±2%	
									Angles ±3°	

JVL
www.jvl.dk

JVL A/S
 Bregnerødvej 127
 DK-3460 Birkerød
 Tel: +45 4582 4440
 Email: jvl@jvl.dk

A4

File name: {file name}

Part no. **W1013-M12M17TF4T.4N**