



Power Supply PSU48-0800



■ Features :

- AC 180~260VAC input
- PF> 0.98@ 230VAC
- Protections: Short circuit/ Overload/ Over voltage/ Over temperature
- Built in remote sense function
- Built-in remote ON-OFF control
- Power good signal
- With parallel function(N+1)
- Can adjust from 20~100% output voltage by external control 1-5V
- Forced air cooling by built-in DC fan
- 3 years warranty



SPECIFICATION

ORDER NO.	PSU48-0800	
OUTPUT	SAFETY MODEL NO.	800S-P048
	DC VOLTAGE	48V
	RATED CURRENT	16A
	CURRENT RANGE	0 ~ 16A
	RATED POWER	768W
	RIPPLE & NOISE (max.) Note.2	480mVp-p
	VOLTAGE ADJ. RANGE	±5.0% Typical adjustment by potentiometer 20% ~ 100% adjustment by 1 ~ 5VDC external control
	VOLTAGE TOLERANCE Note.3	±1.0%
	LINE REGULATION	±0.5%
	LOAD REGULATION	±0.5%
SETUP, RISE, HOLD TIME	800ms, 400ms, 12ms at full load	
INPUT	VOLTAGE RANGE	180~260VAC 260~370VDC see the derating curve
	FREQUENCY RANGE	47~63Hz
	POWER FACTOR	>0.98 / 230VAC
	EFFICIENCY (Typ.)	89%
	AC CURRENT	5.0A / 230VAC
	INRUSH CURRENT (max.)	60A / 230VAC
	LEAKAGE CURRENT(max.)	3.5mA / 240VAC
PROTECTION	OVER LOAD Note.4	105~115% rated output power Protection type : Current limiting, delay shut down o/p voltage, re-power on to recover
	OVER VOLTAGE	110 ~ 135% Follow to output set up point Protection type : Shut down o/p voltage, re-power on to recover
	OVER TEMPERATURE	>100°C / measure by heat sink, near transformer Protection type : Shut down o/p voltage, recovers automatically after temperature goes down
ENVIRONMENT	WORKING TEMP.	-20 ~ +65°C (Refer to output load derating curve)
	WORKING HUMIDITY	20 ~ 90% RH non-condensing
	STORAGE TEMP., HUMIDITY	-20 ~ +85°C 10~95% RH
	TEMP. COEFFICIENT	±0.04% / °C (0 ~ 50°C)
	VIBRATION	10 ~ 200Hz, 2G 10min./1cycle, 60min. each along X, Y, Z axes
SAFETY & EMC (Note. 5)	SAFETY STANDARDS	UL60950, TUV EN60950 Approved
	WITHSTAND VOLTAGE	I/P-O/P:3KVAC I/P-FG:1.5KVAC O/P-FG:0.5KVAC
	ISOLATION RESISTANCE	I/P-O/P, I/P-FG, OP/FG:100M Ohms / 500VDC
	EMI CONDUCTION & RADIATION	Compliance to EN55022 (CISPR22) class A
	HARMONIC CURRENT	Compliance to EN61000-3-2,3
OTHERS	EMS IMMUNITY	Compliance to EN61000-4-2,3,4,5,6,8,11, Light industry level, criteria A
	POWER GOOD SIGNAL	Open collector of NPN transistor
	SPECIAL FUNCTION	DC Voltage Adj., remote sensing, remote control, parallel operation(refer to control terminal instruction manual)
	COOLING	By fan, >20% load or >50°C fan on
	MTBF	74.9K hrs min. MIL-HDBK-217F(25°C)
	DIMENSION	290*120*68mm (L*W*H)
PACKING	2.3kg; 8pcs / 20kg / CARTON	
NOTE	1. All parameters NOT specially mentioned are measured at 230VAC input, rated load and 25°C of ambient temperature. 2. Ripple & noise are measured at 20MHz of bandwidth by using a 12" twisted pair-wire terminated with a 0.1uf & 47uf parallel capacitor. 3. Tolerance : includes set up tolerance, line regulation and load regulation. 4. Current limiting 3 times(1.5s,3.0s,5.0s)Then intelligent auto recovery before shut down 5. The power supply is considered a component which will be installed into a final equipment. The final equipment must be re-confirmed that it still meets EMC directives.	



Mechanical Specification

Unit:mm

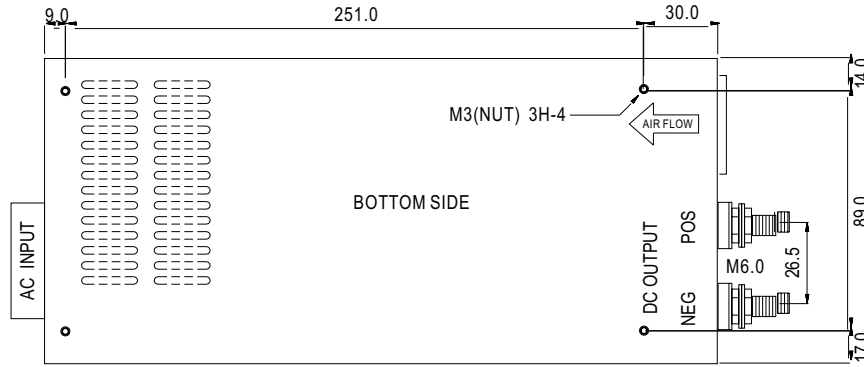
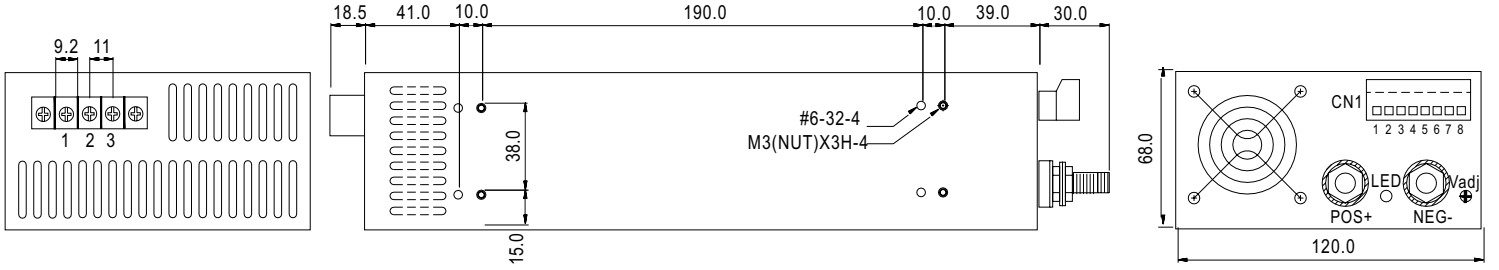

Terminal Pin. No. Assignment

Pin No.	Assignment
1	AC/L
2	AC/N
3	FG \perp

Control terminal Pin. No. Assignment (CN1) : Dinkle 51HDBC-O8P or equivalent

Pin No.	Assignment	Pin No.	Assignment	Mating With
1	VS+	5	PG	Dinkle 51SDB-O8P or equivalent
2	VS-	6	PAR	
3	VCI	7	GND	
4	VCO	8	INH	

Derating Curve

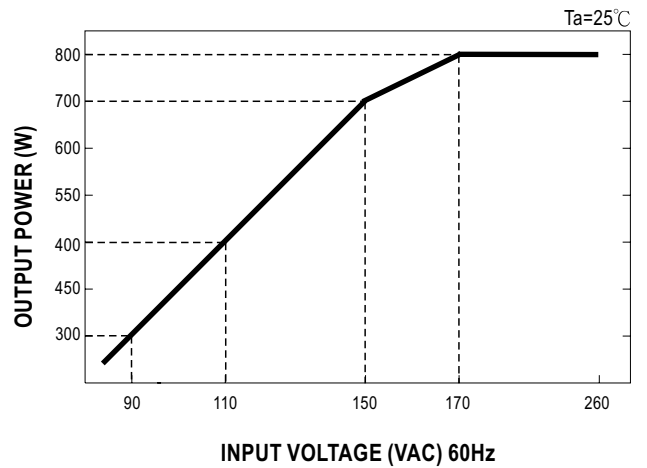
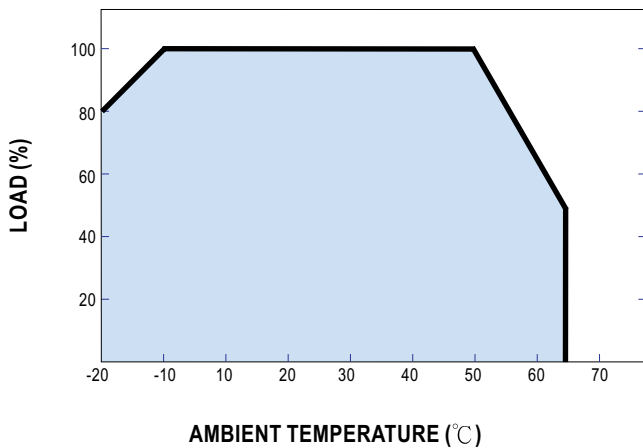

Control terminal instruction manual

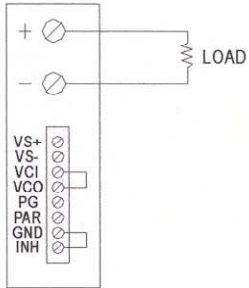

USING INTERNAL VOLTAGE CONTROL

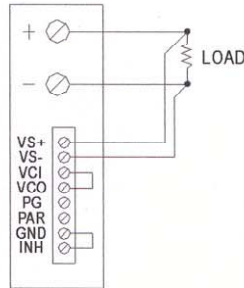

REMOTE SENSING

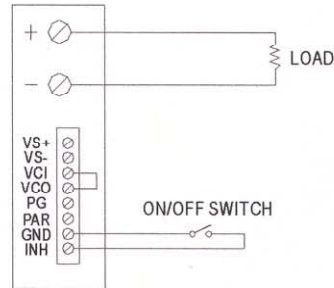

ON/OFF CONTROL BY SWITCH

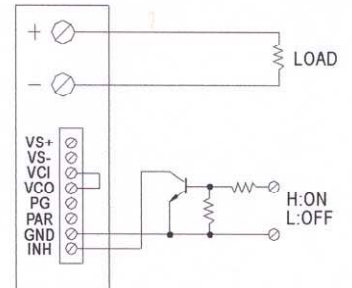

ON/OFF CONTROL BY TRANSISTOR

GOOD : LED OFF
FAIL : LED ON

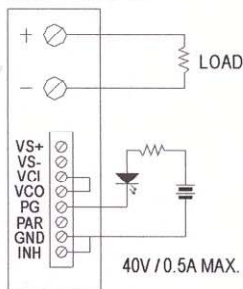

POWER GOOD SIGNAL

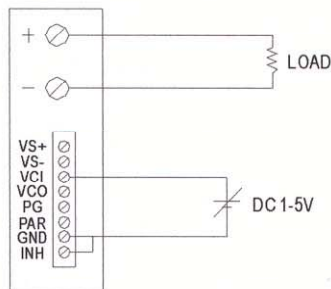

OUTPUT VOLTAGE ADJUST WITH DC 1-5V

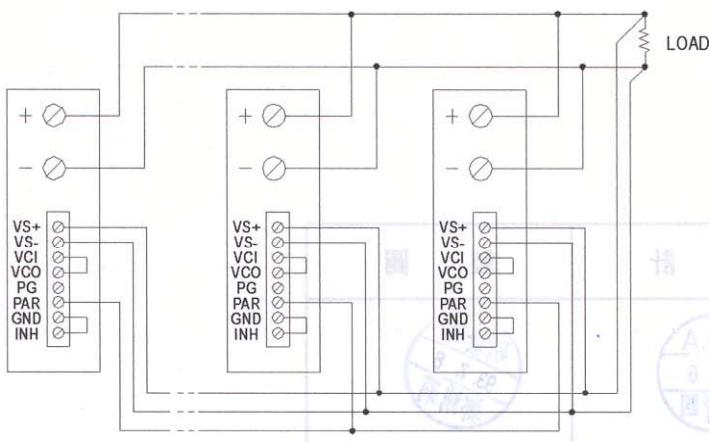
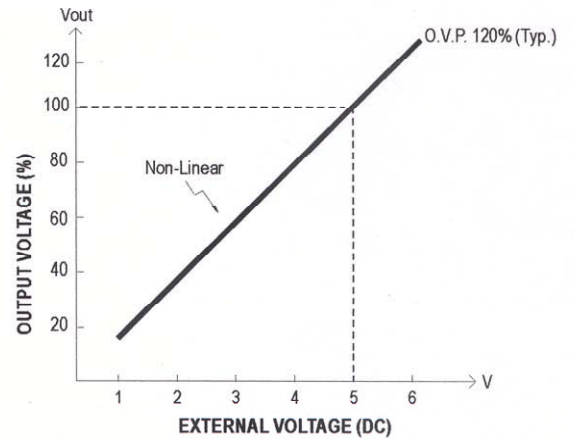

PARALLEL OPERATION WITH REMOTE SENSING

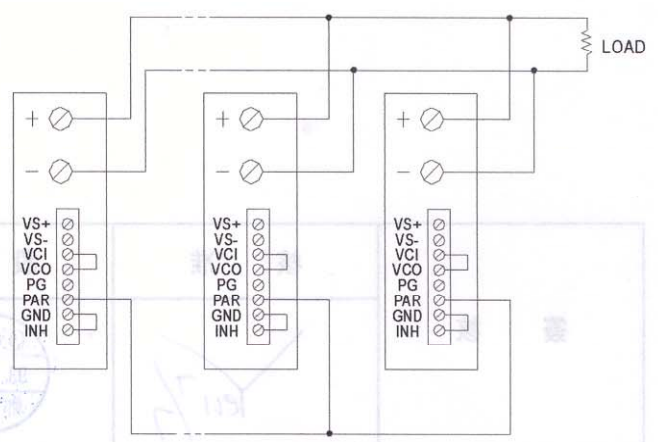

PARALLEL OPERATION WITHOUT REMOTE SENSING