

AC Servo Motor Controllers AMC20, AMC21 and AMC22

AMC20, 21 and 22 are a series of AC Servo Controllers which can be used to control AC motors rated up to 3kW.

The Controllers are based on a 16-bit microprocessor and 32-bit signal processor, and are characterised by great flexibility for a wide range of control applications.

The AMC20/22 controllers can be controlled directly via the built-in RS232/RS485 interface, or indirectly via 6 digital inputs. The Controllers can be directly connected to PLCs equipped with controller modules. They are specially developed also for use with linear motors, with or without hall sensor.

Up to 255 units can be connected to the same RS232/485 bus, and thus a PC or PLC can function as the controller for a multi-axis system.

Using JVL's programming software, MotoWare32, parameters such as motor power, velocity, torque, etc., can be monitored graphically. The AMC 20/22 servo controllers are developed and manufactured in Denmark.

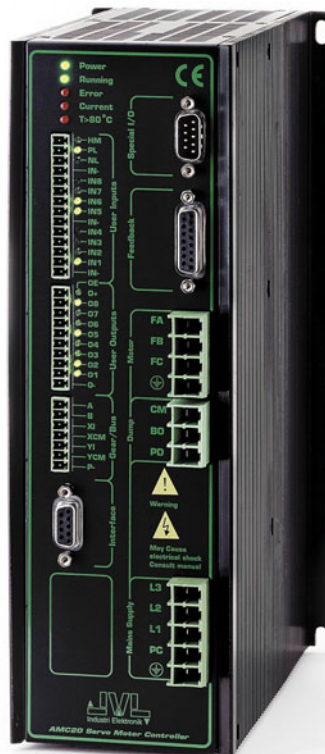

- Built-in mains noise filter
- EMC tested. CE approved
- Built-in RS232/RS485 Interface
- Simple programming with MotoWare32
- Facility for graphic monitoring
- High-resolution electronic gearing
- Can be used for all 3-phase, rotating and linear AC Servo Motors rated up to 3kW
- Unique initialization without hall sensor for no cogging at start up
- Absolute or relative positioning
- Programmable velocity profiles
- Driver stage 1, 2 or 3kW
- Digital control loop
- Fieldbus for external I/O, Display etc.
- 11 inputs, 8 outputs
- IGBT PWM sine-commuted driver
- Short-circuit and thermal overload protection
- $\pm 10V$, pulse/direction inputs
- Versions with JVL-bus, CANopen, CAM profiles and automatic program execution
- Compact:
BxHxD:105x265x175mm





Description (continued)

Servo Controllers AMC20, 21 and 22 are equipped with 11 digital inputs. 6 of these refer to 64 user-defined position and velocity references which are read into registers via the built-in RS232/485 interface. The AMC Controllers can also be velocity-controlled via an analogue input of +/- 10V. In addition, the Controllers can be controlled as a step motor system using step-pulse and direction signals.

A special mode of operation enables electronic gearing at a selectable, keyed-in ratio (from 0.001 to 9999.999) with a resolution of 1 to 1000.

In the standard model, preset values are executed in response to external signals, while in an extended model the Controller itself can perform sequential program execution.

8 general-purpose outputs can be

configured, e.g. to provide a signal when the motor has reached a required position, or to give an error signal if some condition occurs that prevents motor operation.

The Servo Controllers are very easy to program. For example, different velocity profiles can be set by defining acceleration, deceleration (linear or s-curve) and velocity. The Controllers also include built-in programmable end-of-travel limits and a zero-point seek function.

As a signal from a feedback sensor to the digital control loop, the Controllers accept either a balanced or unbalanced signal, for example from a standard 2-channel incremental encoder.

A new feature of these Controllers is the use of FLASH PROM, which enables their basic firmware program to be upgraded at a later date if required.

All inputs and outputs are galvanically isolated and are voltage-overload protected to give high immunity to spurious noise signals. Similarly the Controllers are also protected against thermal overload and short-circuits. The Controllers are designed and constructed to fulfil EMC requirements and are CE-marked. The cabinet is equipped with flanges for easy mounting in a control rack.

The P-version further includes the possibility for automatic sequential program execution and interface for JVL-bus and CANopen bus.

The P-version also includes CAM profiles where in- and output of the CAM can be combined between time, position, velocity, torque, acceleration or register.

	Motor Current (A)	Nominal Power (kW)	Peak Power (kW)	AdvancedProgram Execution	JVL-bus CANopen
AMC20	5	1	3		
AMC21	10	2	6		
AMC22	15	3	9		
AMC20P	5	1	3	X	X
AMC21P	10	2	6	X	X
AMC22P	15	3	9	X	X

Programming and use with MotoWare

Programming of the AC Servo Controllers is easily accomplished using JVL's windows-based programming software, MotoWare. Controller programs are written in a very simple, BASIC-like language and several Controller programs can be opened and edited at the same time. Each Controller program is saved in a separate disk file. Windows show a complete overview of the various parameters. Multiple parameter sets can be saved under their own unique name and these can be retrieved, edited and sent to the Controller. The current set-up of a specific Controller can also be retrieved from the unit and displayed on the screen or saved on the PC. During motor

operation, the current values of motor power, velocity, torque and deviation in position are displayed graphically and can be printed out. This feature can be used for comparison with previously recorded curves and is extremely useful for troubleshooting and checking that the system is operating optimally. MotoWare is supplied on a 3½" diskette, and is easily installed on a PC with Windows 3.1 or higher. Only ½ - 1 MByte of available disk space is required for installation – in addition to an available

COM port for connection of the Controller. The screen display illustrated below shows a velocity and power profile for an AC Servo in operation.

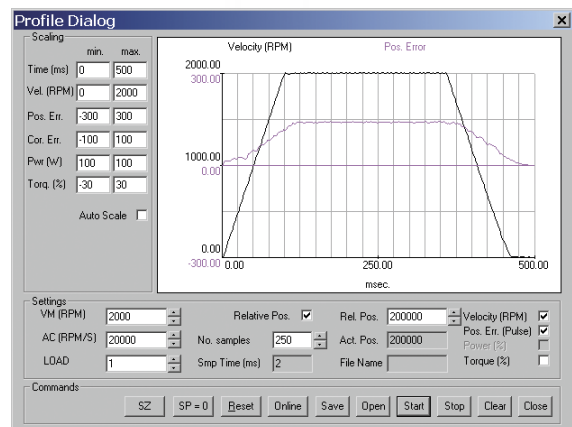

Modes of Operation

Step-pulse Mode

In this mode the Controller functions as in a step motor system. The motor moves one step each time a voltage pulse is applied to the step-pulse input. Velocity, acceleration and deceleration are determined by the external frequency. Use of an encoder enables monitoring and adjustment during motor operation – a feature that is not possible with a standard step motor system. In addition, the AMC Controllers also provide a facility for electronic gearing at a keyed-in ratio.

Positioning Mode

In this mode the Controller positions the motor via commands sent over the RS232/485 interface. Various operating parameters can be changed continuously while the motor is running. This mode of operation is used primarily in systems where the Controller is permanently connected to a PC via the interface. This mode is also well suited for setting up and testing systems.

Register Mode

In this mode the Controller's registers contain the parameter sets, positions, velocities, etc., required for the actual system. The registers can be addressed via the digital inputs and the command executed by activating a start input. This mode provides maximum utilisation of the Controller's features since the Controller itself takes care of the entire positioning sequence.

Velocity Mode

In this mode the Controller controls the motor velocity via the analogue input. This mode is typically used for simple tasks or for applications in which an overall unit, such as a PC-board, controls velocity and positioning.

Torque Mode

In this mode the Controller controls the motor torque using a voltage applied to the analogue input. Typical tasks in this mode include winding or tensioning foil, cable, etc.

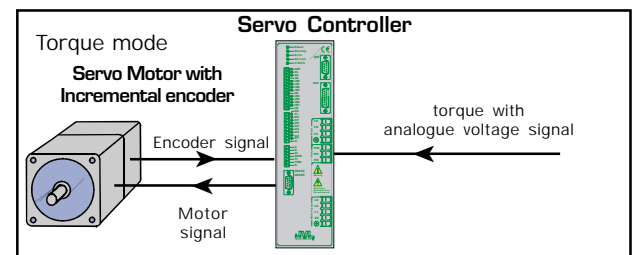
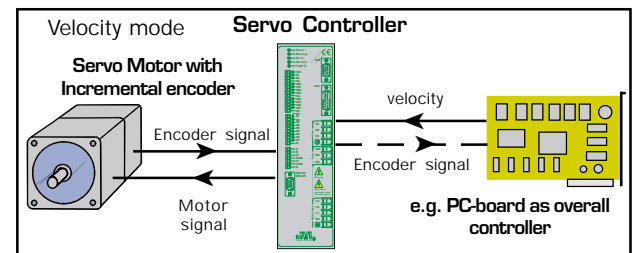
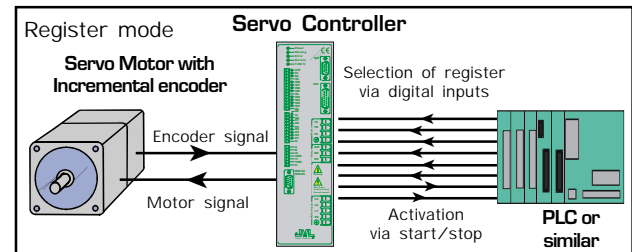
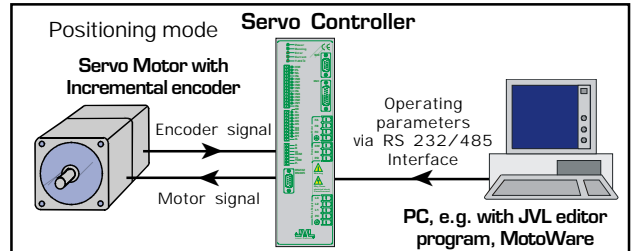
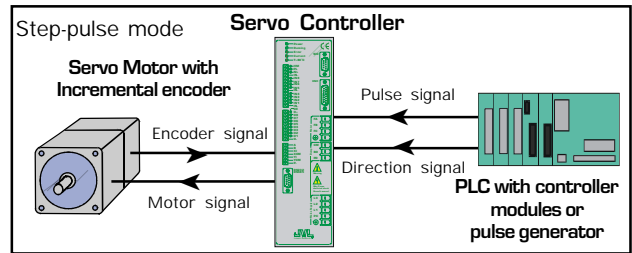

System Configuration

The figure below illustrates typical options for building up a servo system using the AMC Controllers. The PC or PLC is only necessary for programming or monitoring. Thereafter the Controller itself normally controls program execution, possibly in conjunction with a PLC as an overall controller in applications where many different units are controlled interdependently.

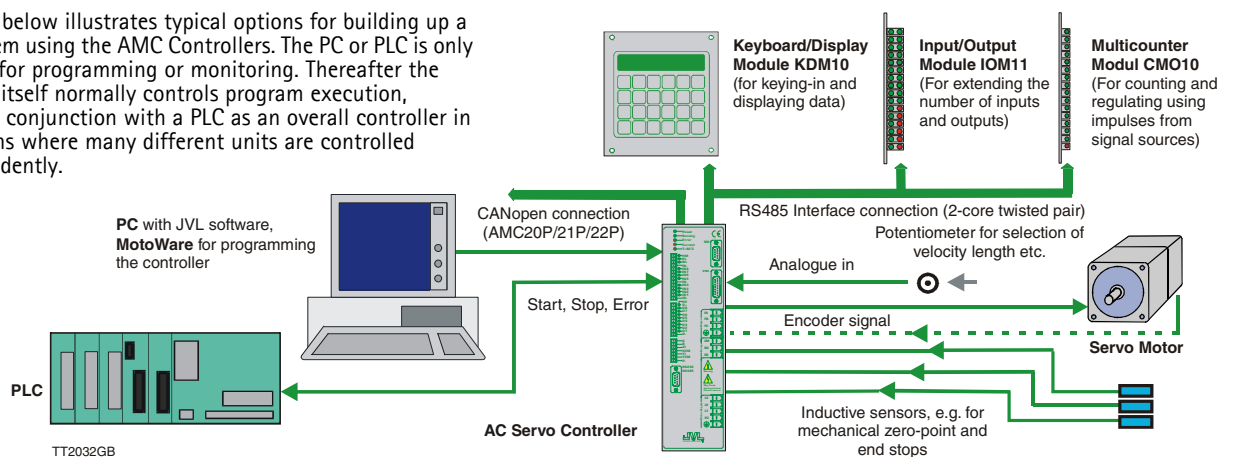



AMC20, AMC21 and AMC22 AC Servo Controllers

Block diagram - functional description

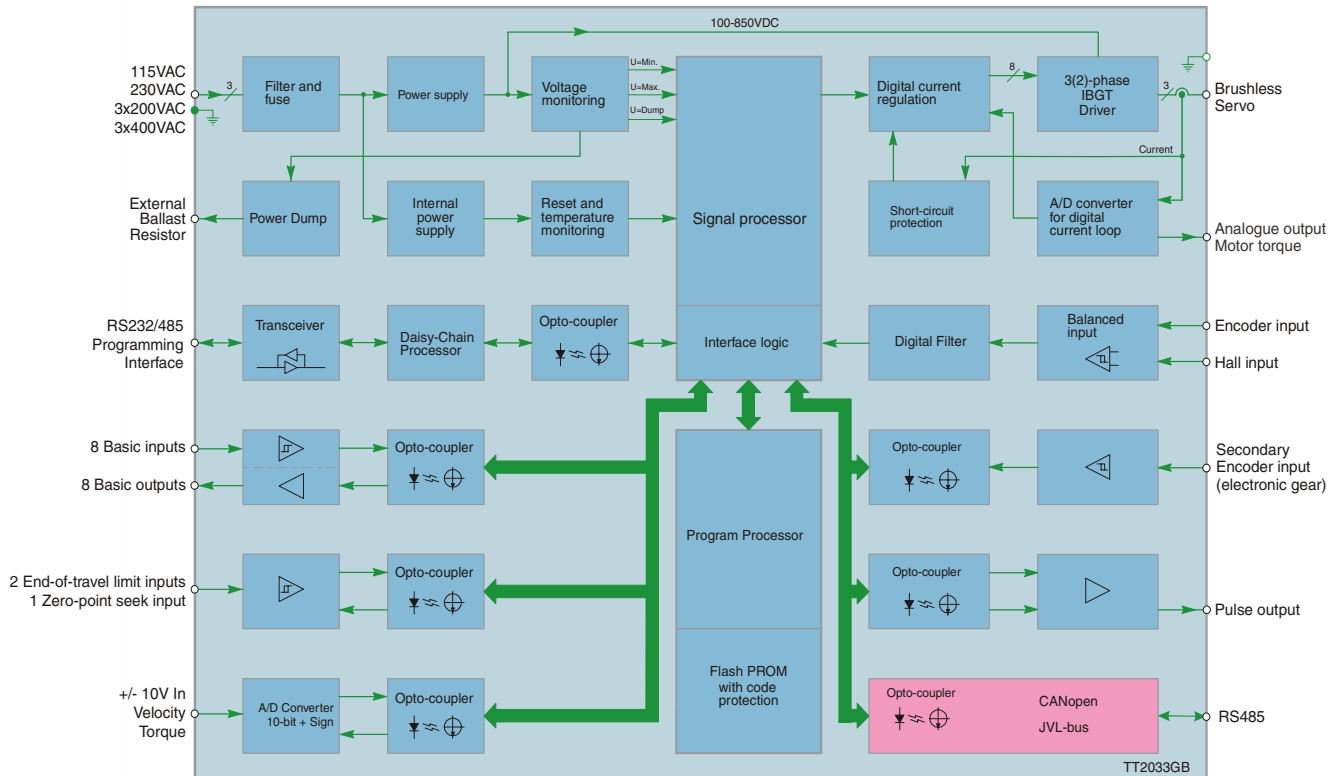

The above diagram gives a schematic representation of the internal structure of the AMC Servo Controllers. All inputs

and outputs are available on the front panel of the Controllers via plug-in connectors. The RS232/485 interface is

available via a 9-pole SUB-9 connector. The front panel is also equipped with LEDs that indicate Controller status.

Technical Data

Description	Min.	Max.	Units
Supply voltage	115	3x400	VAC
Power rating:			
AMC20		1.0	kW
AMC21		2.0	kW
AMC22		3.0	kW
Update time PID-filter		540	µs
Max. power loss in driver	0	100	W
Motor voltage	150	650	VDC
Continous "Power Dump"	-	200	W
PWM frequency	4.9	19.5	kHz
Encoder frequency	0	1	MHz
Pulse input frequency	0	1	MHz
Supply to encoder	4.8	5.2	VDC
Temperature protection	-	80	°C
Operating temperature	0	45	°C
User inputs/outputs	4.5	30	VDC
Weight		4.5	kg

Accessories

Description	Type
Keyboard/Display Module	KDM10
Input/Output Module	IOM11
Multi-counter Module	CMO10
Interface cable (9-pole)	RS232-9-1
Interface cable (25-pole)	RS232-25-1
Programming software	MotoWare32
Profibus Gateway	FBG10
Resolver to Encoder Converter	PA0095



JVL Industri Elektronik A/S
 Blokken 42
 DK-3460 Birkerød, Denmark
 Tel: +45 4582 4440
 Fax: +45 4582 5550
 E-mail: jvl@jvl.dk www.jvl.dk

