

Power Supplies PSU48/12-2 and PSU48/24-2

12VDC to 48VDC and 24 to 48VDC, 144W, 400W

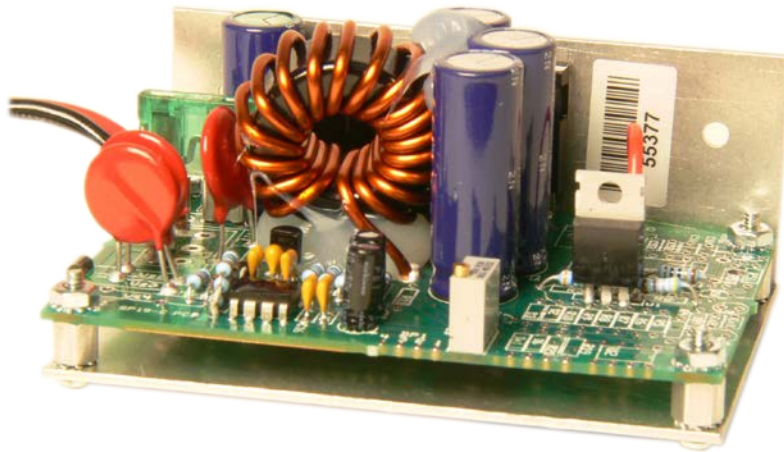

This Power Supply can be used when the supply voltage is 12VDC as for instance a battery. It converts 12 VDC to 48VDC regulated so that a motorcontroller which has to be supplied with 48VDC can be connected directly. For instance can the MAC motor MAC050 to MAC141 series and the QuickStep MIS23x series be connected directly. It is possible to connect 12 VDC to a motor controller but the max. velocity will be limited to approximately 25% and the dynamic capabilities of the motor is decreased considerably.

PSU48/12-2 can deliver 140W continuously and up to 400W peak which matches the requirements of MAC140, which demands 400W in peak. Thereby a reliable and highly dynamic motor system is secured from only a 12VDC supply. If the supply voltage is 24VDC the converter PSU48/24-2 can be delivered.

It is recommended to mount a capacitor, for instance 4700 μ F/50 volt

across the 48V if large peak currents have to be drawn for instance if a MAC140 or MAC141 is used. Thereby the voltage is smoothed out and overshoot that can damage the motor is avoided.

Warning: To be installed and connected by qualified personnel only.

Ensure all power sources are disconnected when making any connections to this unit.

Note: Units are modified to handle high power output for short periods of time. Fuse input and output appropriately. Also, units must be sufficiently heat sunk to dissipate heat. Failure to do so will result in damage.

Introduction

This unit outputs a regulated 48V from a 12 V battery to run a 48V load.

Electrical Specifications

Input Voltage: 11 - 15
(nominal battery)

Lead acid assumed: 12 V nominal

Output Voltage (V) +/- 2%: 48V
Adjustable by internal POT

Output Current (Amps) 3
Short term (2 min.)
Current limited 8.5
(approximately 400W)

Note: limited by fusing characteristics
Input Fuse: Automotive Style: 30 A
Littelfuse ATC-30 or equiv.

Enclosure: None

Quiescent Current: 15 mA

Transient Protection:
All Inputs and Outputs

Efficiency: 92 - 96 %
depending on loading and state of charge

Cable length: 0.35m. Free end.

Power Supply PSU48/12-2 and PSU48/24-2

Mounting

- 1) Determine location of the controller.
- 2) Use holes in L-bracket to mount unit. Heat sink compound is recommended for better transfer of heat.

Connections

Warning: To be installed and connected by qualified personnel only. Ensure all power sources are disconnected when making any connections to this unit.

Connect Ground

Using wire of sufficient gauge (min. #12 AWG), connect the Battery input negative and the controller black lead together to the load negative.

Input = Connect to Battery negative + load negative = Black.
This is a common negative connection

WARNING: To avoid flash or burn injuries, extreme care must be taken

when making battery connections. Do not short the battery or output.

Connect Load Battery Positive

Using wire of sufficient gauge (min. #12 AWG), connect the white lead to the Load + wire, environmentally seal connections if required.
Load + = white this is the 48 V connection

Note: Fuse to protect load. Since the unit is capable of putting out up to 8 amps of current in short bursts, a slow blow fuse can be used of a lower amperage

LAST CONNECTION: Connect Battery +

Using wire of sufficient gauge (min. #12 AWG), connect the red lead to the battery or power source; environmentally seal the connections if required.

NOTE: There will be a small spark as the battery charges the internal

capacitors.

WARNING: To avoid flash or burn injuries, extreme care must be taken when making battery connections. Do not short the battery or output.

Input Bat + = Red
This is the 12 V battery connection

Note: Fuse as necessary

Voltage Adjustment

The output voltage of this unit may be adjusted by removing the lid and adjusting the internal adjustment POT (small blue square part with a slot drive on its top). While monitoring the output voltage, adjust the POT to achieve the desired output voltage.
Note: If the attempted output voltage is .5 V less than the input voltage, the adjustment POT will have no effect. Turn the POT CW for more voltage, CCW for less voltage.

Measurements:

L x W x H
96,6 x 66,6 x 47,5. 40mm cable.

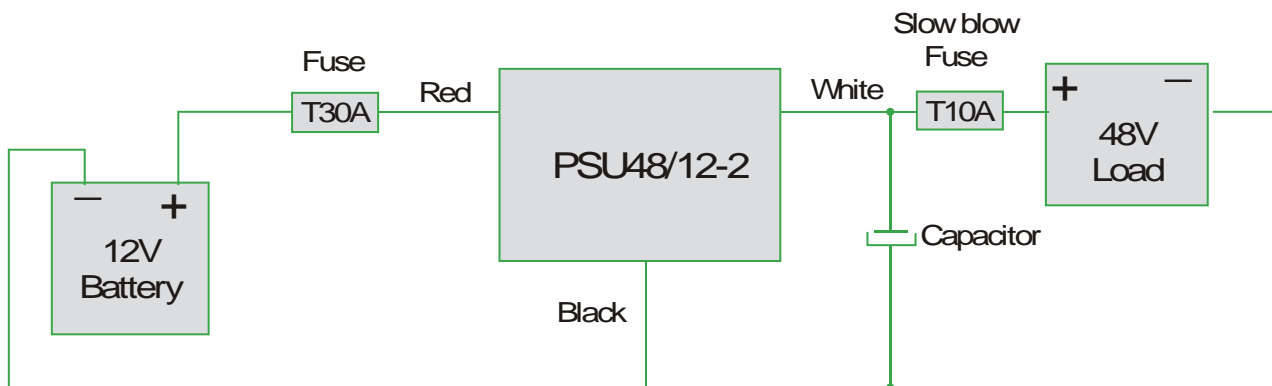

TT2272GB



JVL Industri Elektronik A/S
Blokken 42
DK-3460 Birkerød, Denmark
Tel: +45 4582 4440
Fax: +45 4582 5550
E-mail: jvl@jvl.dk www.jvl.dk