

QuickStep

- the integrated stepper motor

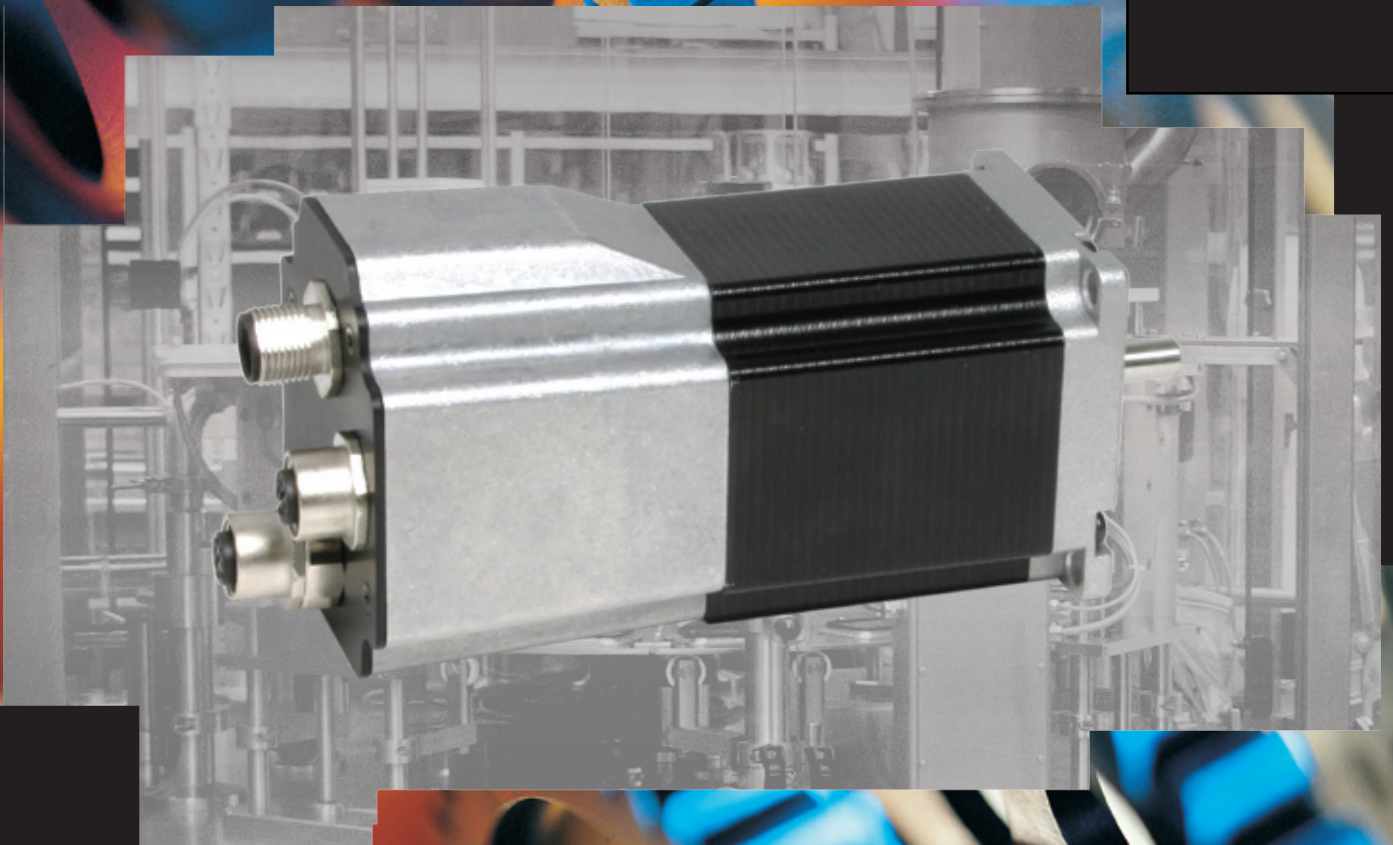

**The simple and economic way
of motion control**

*Stepper motors with
integrated controller*



Choose between the three: N

1.1 Nm, 1.6 Nm

The QuickStep series of stepper motors with integrated electronics represents a major step forward. All the necessary electronics in a stepper system are integrated in the motor itself.

In the past, a traditional motor system has typically been based on a central controller unit located remote from the motor. This configuration however has the negative effect that installation costs are a major part of the total expense of building machinery.

The basic idea of the QuickStep motors is to minimize these costs but also to make a component that is much better protected against electrical noise which can be a typical problem when using long cables between the controller and motor.

The stepper motor, encoder and electronics are specially developed by JVL so that together they form a closed unit in which the power driver and controller are mounted inside the motor in a closed section.

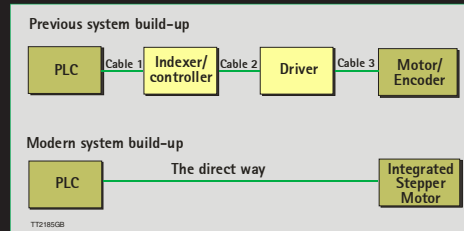

The advantages of this solution are:

- De-central intelligence.
- Simple installation. No cables between motor and driver.
- EMC safe. Switching noise remains within motor.
- Compact. Does not take space in cabinet.
- 12-48VDC power.
- Low-cost alternative to separate step or servo motor and driver.

Interface possibilities to the QuickStep motor:

- From PC/PLC with serial commands via RS485 or CANopen. Prepared for DeviceNet.
- Pulse/direction or encoder input.
- μ PLC built-in with graphical programming.
- 8 I/O, 5-28VDC that can be configured to Inputs, Outputs or Analogue Inputs
- Future option for Profibus DP, Ethernet, Bluetooth and Zigbee wireless.

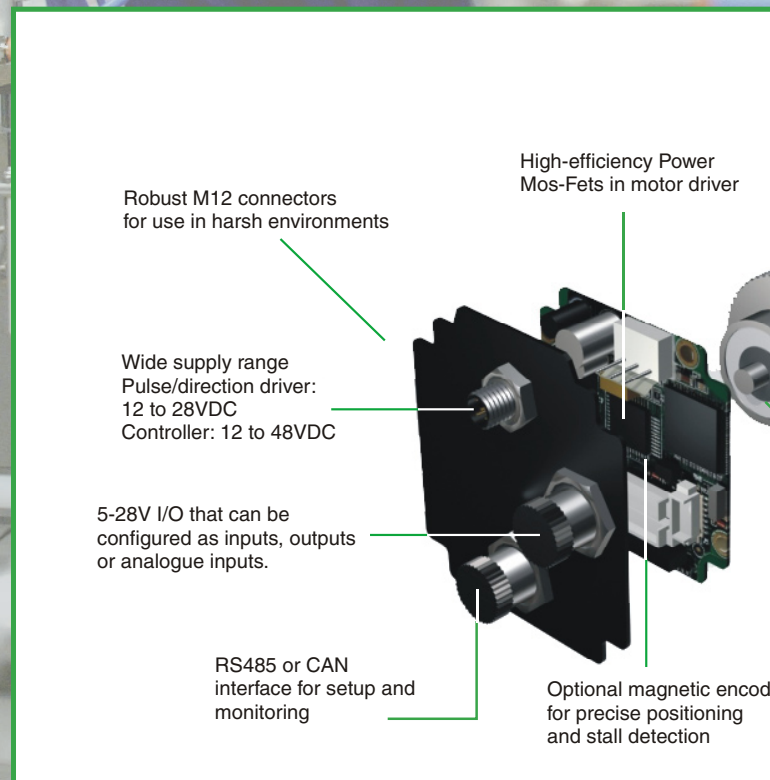
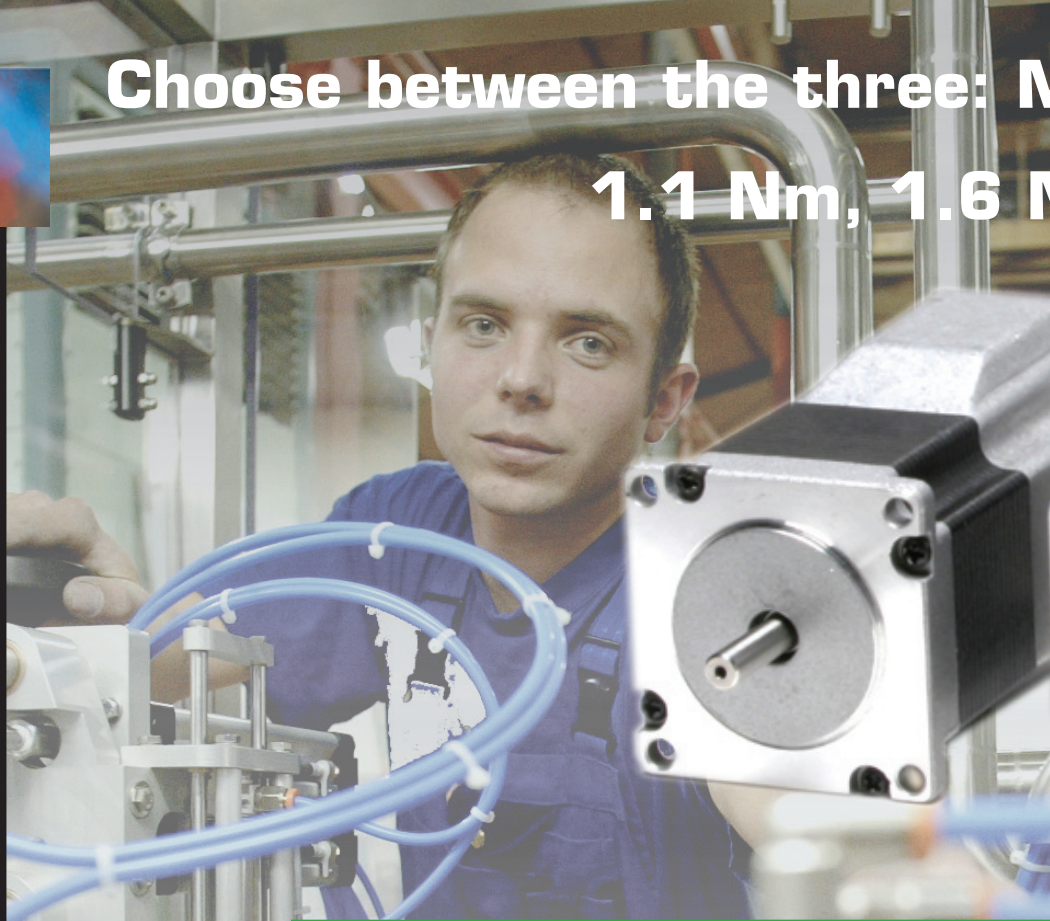

Pulse/direction

Input for pulse/direction signal 5-24VDC or PNP/NPN. The driver is the wellknown SMD73. Supply voltage is 12 - 28VDC. 1/1, 1/2, 1/4, 1/5 and 1/8 ministepp available.

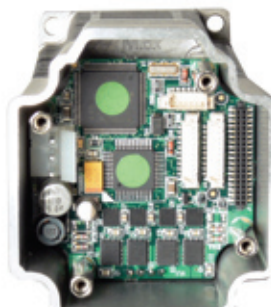

Positioning or Speed Control

Built-in μ processor with 8 In/Out that can be configured as inputs, PNP outputs or analogue inputs. Serial RS485 interface for set up and programming. Option for CANbus, CANopen 402. Prepared for DeviceNet. Driver is SMC75 with improved technology as compared to SMD73. Supply voltage is 12-48VDC.

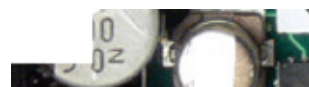

MIS231, MIS232 or MIS234

1.1 Nm or 2.9 Nm

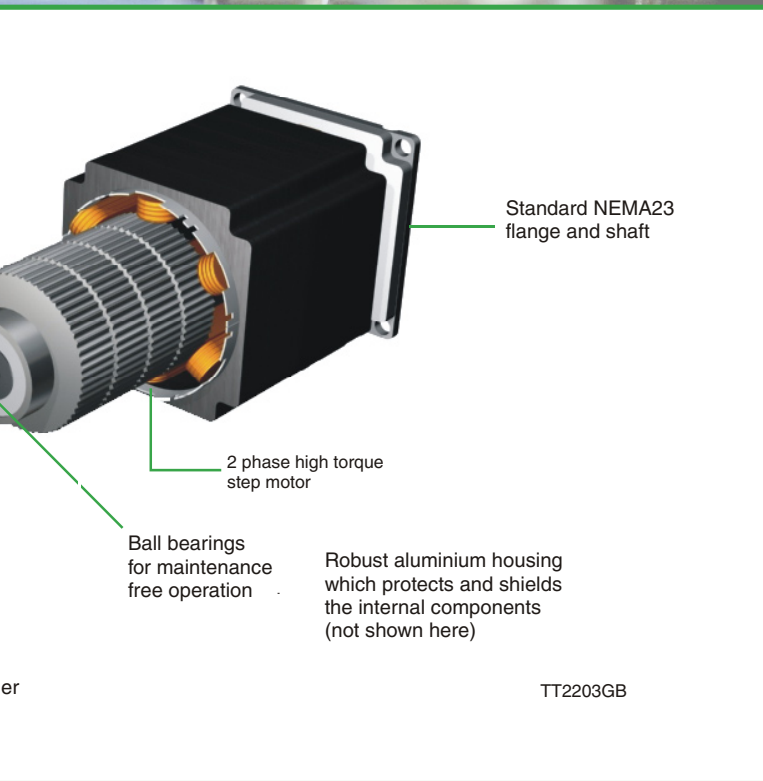
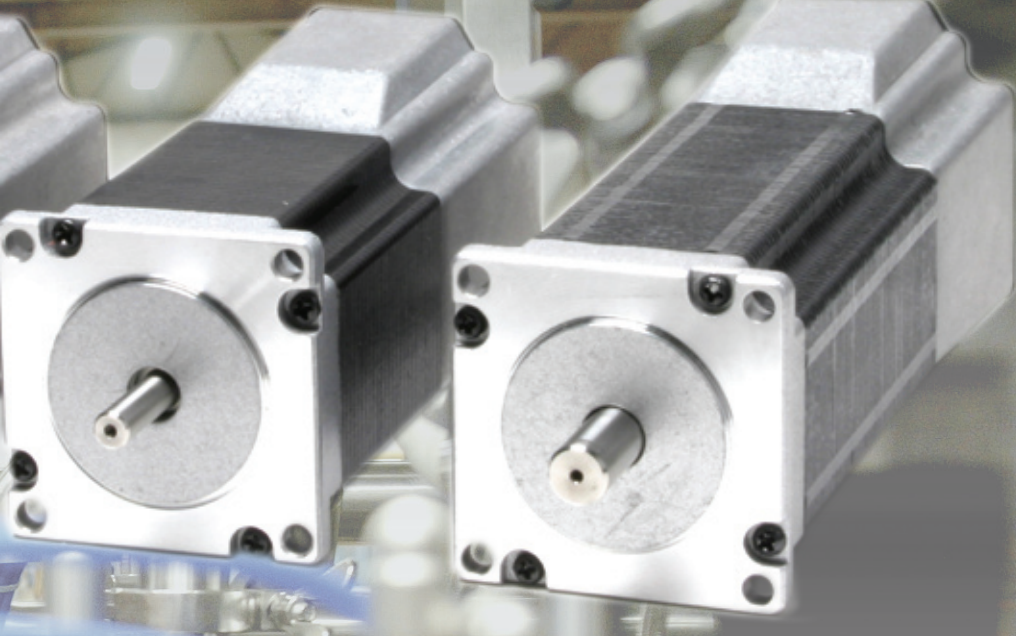

QuickStep is a new series of motors from JVL which can be delivered with a large selection of functions and in a wide variety of combinations. The base is a high-torque NEMA23 step motor with a housing so that IP55 or larger protection can be achieved. One or more circuit cards and different connectors can be mounted in the housing to adapt the motor to a given task.

- Stepper motor without electronics. Optional with encoder.
- Pulse/direction driver
- Serial RS485 position controller
- Position controller with graphic programming Canbus or CANopen 402. Prepared for DeviceNet
- Stall detect by means of magnetic encoder with resolution of up to 1024 pulses/rev.
- All modules can be delivered with M12 connectors, cable glands or, by larger orders, connector chosen by customer.
- A double supply facility is available so that position and parameters are maintained at emergency stop
- MAC motor protocol so MAC motor and QuickStep motors can be connected on the same RS485 bus
- Commands for easy PLC/PC setup and communication
- Power supply 12-48VDC
- 1,1Nm, 1,6Nm or 2,9Nm versions
- Fixed 1600 pulses/rev. for version with built in controller
- 200, 400, 800, 1000 or 1600 pulse/rev. resolutions for version with pulse/direction inputs.

Low cost planetary gears and worm gears can be delivered from stock.

Stepper motor controller/driver

The QuickStep motors with positioning and speed control includes stepper motor controller SMC75. The QuickStep motors with pulse/ direction includes stepper motor driver SMD73. Both SMC75 and SMD73 can also be delivered as independent units in their own housing for use with a separate motor.

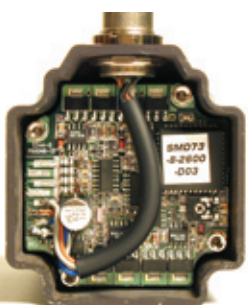

MAC Talk, the software that makes it easy

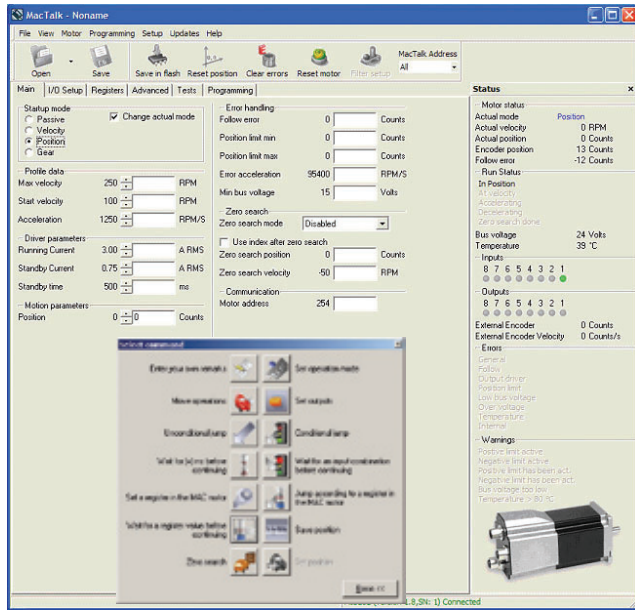

The MacTalk software is the main interface for setting up the QuickStep motor for a specific application.

The program offers the following features:

- Choice of the operating mode of the motor.
- Changing main parameters such as speed, motor current, zero search type, etc.
- Monitoring the actual motor parameters in real time, such as position, velocity supply voltage, input status, etc.
- Changing protection limits such as position limits.
- Saving and restoring all current parameters to disc or to the motor.
- Updating the motor firmware or MacTalk software from the internet or a file.
- Program the motor in a graphical environment with "Wait" and "IF" commands. 8/I/O can be used to control program flow. Arithmetic functions like +, -, *, / available.

The main window of the program changes according to the selected mode, thus only showing the relevant parameters for operation in the selected mode.

QuickStep in a network

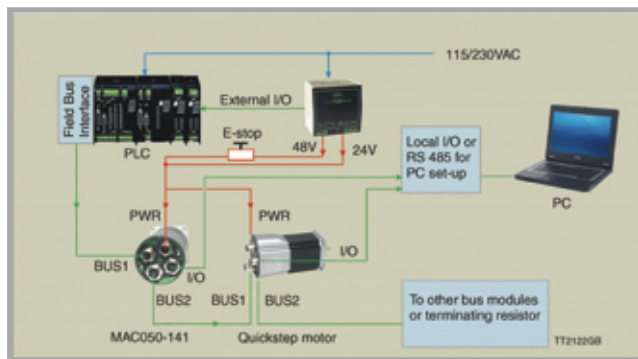

Specifications

Motor Type no.	MIS231	MIS232	MIS234	Unit
Supply Voltage (position)	12-48	12-48	12-48	VDC
Supply Voltage (pulse/dir.)	12-28	12-28	12-28	VDC
Typical Supply Current @24V/48V	2.2/2.1	2.2/2.2	2.5/2.0	ARMS
Speed Range	1-1023	1-1023	1-1023	RPM
Rated Mechanical Power (max.)	74	85	77	W
Cont. Torque	1.1	1.6	2.9	Nm
Rotor Inertia	0.3	0.48	0.96	kgcm ²
Length	96	118.5	154.0	mm
Shaft dia.	6.35	6.35	10.00	mm
Weight	0.900	1.230	1.823	kg
Protection Class	IP42/IP55			

Torque versus speed

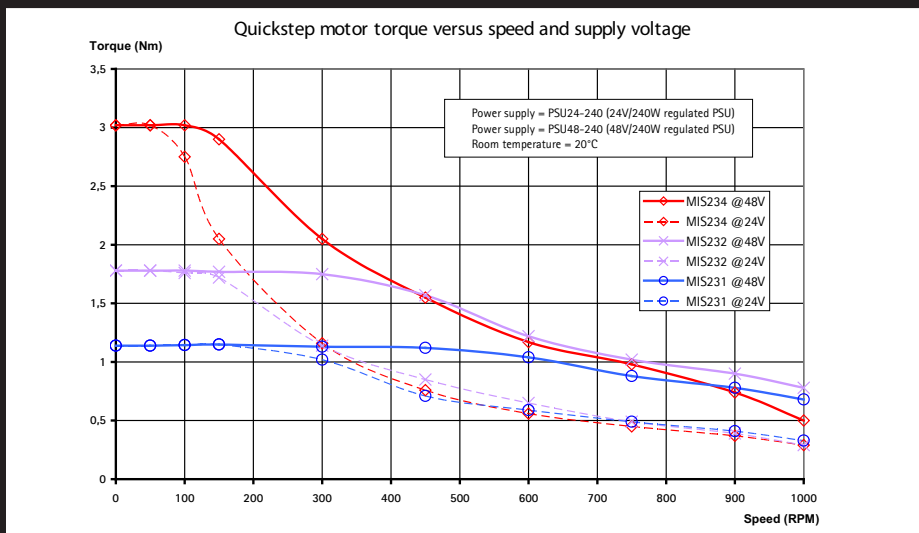

JVL Industri Elektronik A/S
 Blokken 42
 DK-3460 Birkerød, Denmark
 Tel: +45 4582 4440
 Fax: +45 4582 5550
 E-mail: jvl@jvl.dk www.jvl.dk

JVL Germany
 Tel. +49 7821 920 52 60
 Fax : +49 7821 920 52 61
 E-mail: ob@jvl.dk www.jvl.dk

JVL UK
 Tel. +44 1354 695558
 Fax. +44 1354 694918
 E-mail: arp@jvluk.com www.jvluk.com